

Reconstruction of a torsion balance and the results of the test measurements

L. Völgyesi

Department of Geodesy and Surveying, Faculty of Civil Eng., Budapest University of Technology and Economics; Research Group of Physical Geodesy and Geodynamics of the Hungarian Academy of Sciences. PO Box 91, H-1521, Hungary

Z. Ultmann

Department of Geodesy and Surveying, Faculty of Civil Eng., Budapest University of Technology and Economics PO Box 91, H-1521, Hungary

Abstract. During recent investigations concerning geodetic applications of the torsion balance measurements several problems arose, which required performing new torsion balance measurements. For that reason an Eötvös-Rybár (Auterbal) torsion balance, which has been out of operation for many decades, was reconstructed and modernized. The scale reading has been automated and its accuracy has been improved by using CCD sensors. Calibration and processing of field measurements were computerized to meet today's requirements. Test measurements have shown that this instrument was able to work according to the expectations of our age.

Keywords. Eötvös torsion balance, CCD sensors, reconstruction, calibration, test measurements

1 Introduction

The first torsion balance field measurements were made between 1901 and 1903 by Lorand Eötvös and his colleagues. Afterwards, until 1960's about 60000 points were measured on the flat and semi hilly areas for geophysical prospecting by the Hungarian-American Oil Company (MAORT), Lorand Eötvös Geophysical Institute of Hungary (ELGI) and the National Oil and Gas Co. Ltd. (OKGT) (Polcz, 2003). Because of the former measurements were made for geophysical purposes, so only the horizontal gradients W_{zx} , W_{zy} were used, and the curvature gradients W_{yx} and W_{Δ} – which are very important for geodesy – left unprocessed. Unfortunately some data of the former measurements are lost, but many of them are available as on original field books or maps. From the year 1995 the experts of the Lorand Eötvös Geophysical Institute make lots of efforts to save those data to computer database by the financial support of the Department of Geodesy and Surveying of the Budapest University of Technology and Economics. At present more,

than 36500 valuable gradient data are waiting in this database for the further processing mainly for geodesy.

2 Geodetic applications of the torsion balance measurements

Lorand Eötvös made simultaneously with his first measurement a special computation method to determine the change of deflection of the vertical between two points used the curvature gradients W_{Δ} and W_{xy} (Eötvös, 1906). If we know the observed values of deflection of the vertical in some points of an area by astrogeodetic method, than values of the deflection of the vertical can be interpolated on every torsion balance points. At the same time using the interpolated values of the deflection of the vertical, applying the method of astronomic leveling, it is possible to determine the geoid heights (Völgyesi, 2001a), – so using torsion balance measurements we are able to determine the fine structure of the geoid. Nowadays the computation method of Eötvös was successfully improved with the aid of the modern mathematical and computational methods (Völgyesi 1993, 1995, 2005, Völgyesi et al 2005) and we are able to determine the deflection of the vertical and the local geoid shape even more accuracy.

Improvements of the new computational methods give new possibilities for geodetic application of all elements of the Eötvös tensor. Besides the geodetic application of the curvature data the horizontal gradients of gravity measured by torsion balance can be used for geodetic purposes too. Because the knowledge of the real gravity field of the Earth has a great importance in physical geodesy, the possibility and the need for the usage of these horizontal gradients are important. Using these gradients combined with gravity or gravity anomalies the components of the local gravity field especially the low-degree components can be reproduced (Völgyesi-Tóth-Csapó, 2004).

Knowledge of the vertical gradients is very important for different kind of purposes in geodesy too, but according to our researches, the real value of this vertical gradients significantly differ from the normal one (Csapó-Völgyesi, 2004). Moreover this is the only component of the Eötvös-tensor which is not observable by torsion balance. Because the classical determination of the vertical gradients directly by gravimeters is rather time consuming and expensive process so another more simply and not so expensive method is necessary.

Torsion balance measurements give new possibility to determine vertical gradients by an interpolation method. Starting from curvature and horizontal gradients of gravity measured by torsion balance, the T_{zx} , T_{zy} horizontal gradients and the $T_{\Delta} = T_{yy} - T_{xx}$, $2T_{xy}$ curvature data of the disturbing potential $T = W - U$ can be formed, and according to Haalck method (1950) the vertical gradient T_{zz} can be determined from these value (Tóth-Völgyesi-Csapó, 2004). This method, similarly to the astronomical leveling, generates differences of vertical gradients at least between three points measured by torsion balance. For this interpolation it is necessary to know the real (observed) value of vertical gradients in some points of the area.

Another new important geodetic application of torsion balance measurements is the 3D inversion reconstruction of gravity potential based on gravity gradients. This new inversion method gives opportunity to determine the function of gravity potential and their all first and second derivatives (the components of gravity vector and the elements of the full Eötvös tensor – including the vertical gradient) (Dobróka-Völgyesi, 2008). Comparing the elements of the computed Eötvös tensor to the gravity gradients measured by torsion balance gives a good opportunity to control the inversion. Hereby an opportunity presents itself for the analytical determination of the potential surfaces.

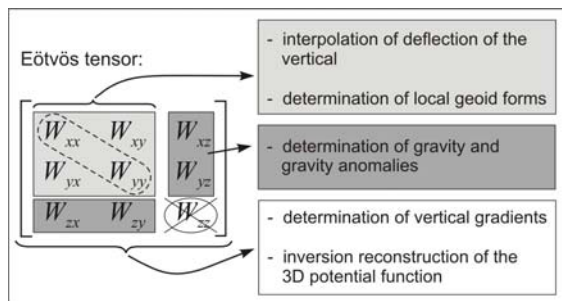

Fig 1. Geodetic application of gravity gradients

All the geodetic applications of torsion balance measurements are summarized on Fig. 1. On the left-hand side of the figure the elements of Eötvös-

tensor are arranged to three groups: curvature data are indicated with light-gray shading, horizontal gradients of gravity are marked by dark-grey shading (these can be measured directly by torsion balance) and the crossed element (the vertical gradient) on the right hand side of the Eötvös tensor, is not measurable directly by torsion balance. On the right-hand side of Fig. 1 the types of the possible geodetic applications are shortly summarized.

3 Necessity of further measurements

In the latest time some new special problems arose in our researches about the geodetic application of gravity gradients, which necessitates new torsion balance measurements. The most important reason is coming from the determination of vertical gradient. As we mentioned a new interpolation method is developed based on the Haalck's (1950) idea to determine W_{zz} using torsion balance measurements (Tóth et al 2005, Tóth 2007). We have controlled our method by synthetic data, but the full control with real data is still missing. For this purpose such points are needed, where both torsion balance measurements and vertical gradient observations are available. Unfortunately vertical gradients were not measured on those points where torsion balance was used; on the other hand coordinates of earlier torsion balance points are not known the required accuracy. A good opportunity presents itself in the Mátyás cave in Budapest, where a special micro-base network of the Lorand Eötvös Geophysical Institute of Hungary can be found. This network contains 14 points where former vertical gradient measurements are available, and the area is extremely suitable for torsion balance measurements (Csapó, 1991).

4 Preparation of the instruments

Recently there are two types of former manufactured torsion balances which are still capable for field measurements. One of them is the Eötvös-Rybár (Auterbal) balance, which was developed to the end of 1920's; the other is the improved E54 type manufactured in 1954. A short basics about torsion balance can be found in (Völgyesi, 2001b).

The E54 torsion balance of the Lorand Eötvös Geophysical Institute has been renewed by the specialists of the institute. Unfortunately it turned out that the narrow measuring range of E54 instrument was not suitable for the measurements in the Mátyás cave because of the huge gravity gradient values. So only the Auterbal torsion balance with wider measuring range has remained the applicable instrument for the observation in the Mátyás cave.

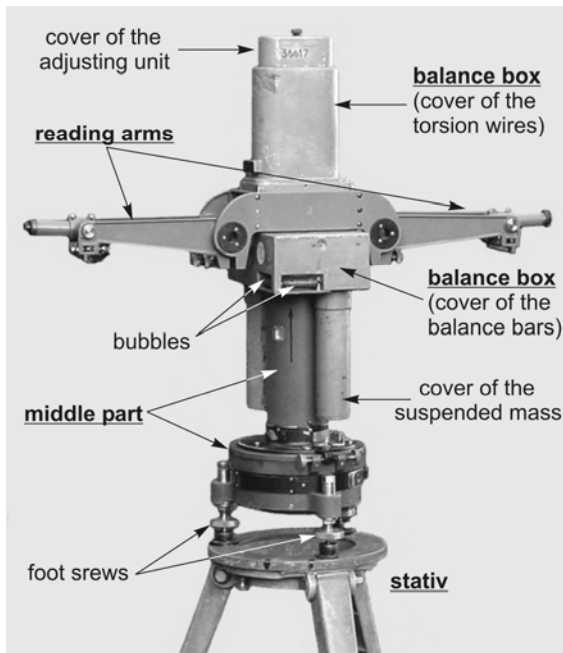

Fig. 2. The Auterbal torsion balance

An Auterbal torsion balance could be found in the museum of the Department of Geodesy and Surveying of the Budapest University of Technology and Economics. After a long field work this instrument was donated to the department by the Lorand Eötvös Geophysical Institute in 1964 for educational purposes. Later this torsion balance went wrong and it has been located in the museum of the department. Many years after, in 2008 we examined the condition of the instrument, and we have found the nearly 80 years old Auterbal torsion balance to suffer several problems, but the torsion wires were not broken. We did not know anything about the main spring, which has been spanned over 40 years.

Repairing seemed to be a serious problem because there was not any description about this instrument. The first challenge was to guess the steps of dismantling and assembling, and to find out the functions of the many screws fixing elements and parts. We should have to be very careful at the first steps of dismantling because of the spanned main spring (which helps the turning of the torsion balance to the different azimuths) might caused serious damages. For our fortune after separating the balance box and the middle part of the instrument (see Fig. 2) at the beginning of the dismantling the release of the spanned main spring was succeeded and considering carefully all the other steps of dismantling at last we were able to remove the damaged clockwork. The prepared clockwork can be seen on Fig. 3. After changing damaged parts and repairing and refashioning of the clockwork further

several improvements were carried out too. CCD sensors were supplied on both reading microscopes for automatic readings and special strong LED light was installed for lighting the scale (see Fig. 4). Controlling and processing the CCD readings special computer software was developed under Linux operation system. Applying the new reading system new possibilities was born for very fast readings which were impossible before, e.g. detailed investigation of attenuation of the oscillation and studying of the long scale drift became possible.

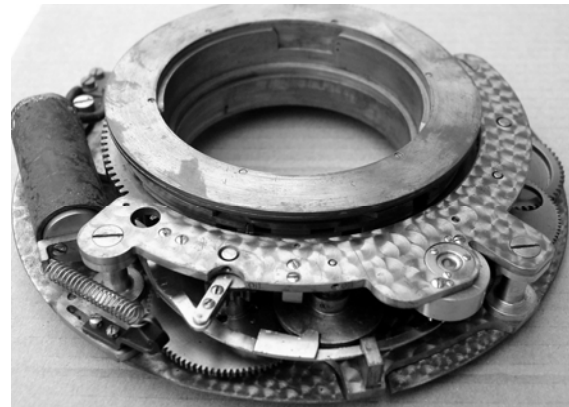

Fig. 3. The clockwork for turning the torsion balance

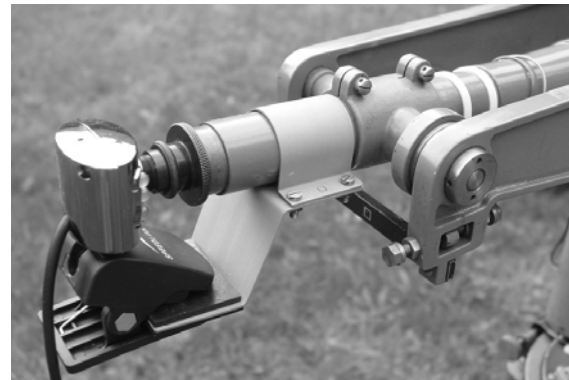

Fig. 4. CCD camera for scale reading

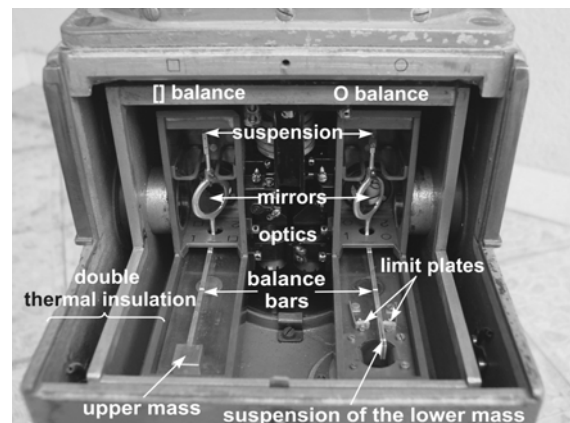

Fig. 5. Inner construction of the Auterbal balance

5 Fine tuning of the instruments and the test measurements

If we want to understand the essence of the fine tuning, the inner construction of the torsion balances has to be known. Both Auterbal and E54 instruments contain two independent antiparallel torsion balances inside the balance box (see Fig. 5). The two antiparallel balances are being enclosed in a double walled heat-insulating box. The aluminum balance bars are connected to the torsion wires through reading mirrors. Diameter of torsion wires are 0.017 mm (diameter of a most thin hair is about 0.02 mm). On Fig. 5 the brick-shape upper mass can be seen on the left side balance bar while on the other right side parallel balance bar the fixing place of the lower suspended mass can be seen. For the purpose of the exact identification one of the two antiparallel torsion balances are marked by circle (“O”) and the other by square (“[”). The oscillation range of balances can be regulated by the limit plates, as it can be seen on the Fig. 5, the angle of the oscillation amplitude is smaller than $\pm 2^\circ$.

Before the first field observations some special test measurements was required to control the functioning and behavior of the repaired and modernized torsion balances. The most important question was the drift of the torsion wires. (Drift is the small continuous changing of scale reading because of the small one-way twisting of a torsion wire.) Drift can be explained based on the knowledge of the solid state physics. If a torsion wire is in excellent condition, the balance bar of the torsion balance remains at the same position for a long time, in other cases the balance bar is turning a little bit in time, so scale reading is changing permanently. Reduction of the drift can be achieved by the heat treatment and by spanning (hanging) the torsion wires for a long

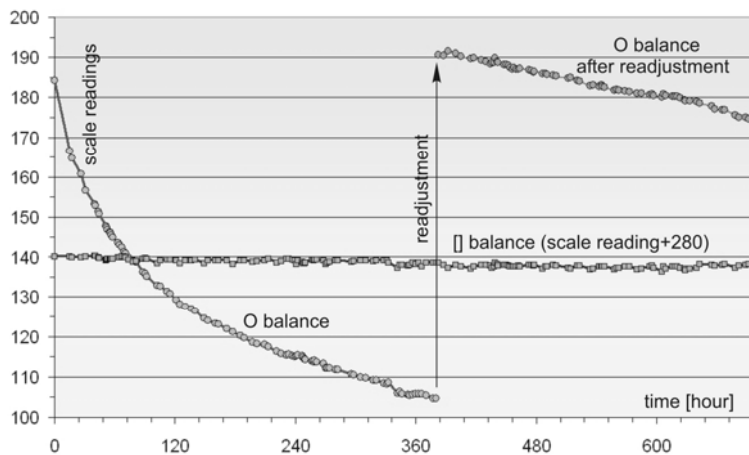

Fig. 6. Shape of the drift curve after the renovation of the Auterbal torsion balance

time. After the renovation of the torsion balance, the drift was controlled over 30 days by the readings 10 times a day in the same azimuth.

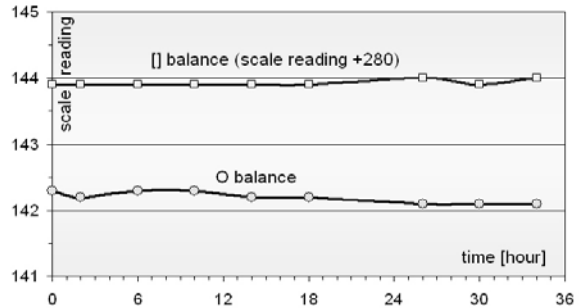

Fig. 7. The drift curve after the treatment of the torsion wire

Results on the first day were alarming: as the [torsion wire seemed to be in excellent condition, than the drift of the O wire was enormous: readings were fallen more than 20 scale unit in the first 24 hours. After a few days the situation become not so bad, the incline of the drift curve started to be smaller and smaller, which is shown on the Fig. 6. Two weeks later the reading was changed just 1-2 scale units a day, but a new adjustment of the torsion wire was necessary because the zero position of the balance bar turned extremely towards to the lower limit. (Adjustment of a torsion balance means a very small turning or moving up and down of the balance bar to reach the middle/zero position.) At this time the O balance bar have been a little beat overturned, because further permanent decreasing drift was expected (see Fig. 6). Because the permanent drift really stayed further on, so the torsion wire was taken out from the instrument for a purpose of a detailed investigation. We have found a problem about the fixing of the torsion wire so we resoldered it to the right position. The permanent

drift was stopped by a certain extent opposite turning with a tiny loading and than by a long time suspension. The treatment was successful the smooth drift curves can be seen on the Fig. 7 after the treatment of the O torsion wire.

Important experiences came from the investigations of the relation between the temperature changing and the reading data. The main task was to determine the necessary waiting time for the first reading after the release of the balances in case of taking out the instrument from the storage and setup on the field with different temperature. Result of this investigation can be

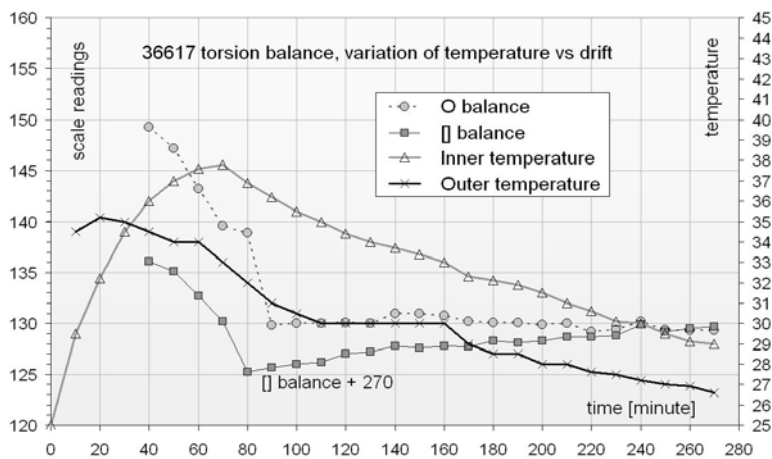

Fig. 8. Relation between the temperature changing and the scale readings

seen on Fig. 8. Based on the figure it can be stated, that the applied 40 minutes waiting time for the first reading after releasing is not enough because the thermal equilibrium, when the drift become already linear ensures during 90 minutes. Further investigations were executed referring to the correction of the readings depending on the variation of the temperature. These investigations have not been finished yet further examinations are necessary. Torsion balance reacts very sensible to several tenth degree temperature variations. According to our experiments while the slow variations are caused by the temperature sensitivity of torsion wires than the quick variations came mainly from the thermal expansion of reading arms

6 Measurements in the Mátyás cave

As we mentioned in the part 3 the torsion balance measurements were made on the gravity microbase points of the Geodynamical Laboratory of Lorand Eötvös Geophysical institute in the Mátyás cave. The map of the Geodynamical Laboratory in the cave can be seen on Fig. 9, where the places of the 14 microbase points and the gravity basepoint of Hungary are shown.

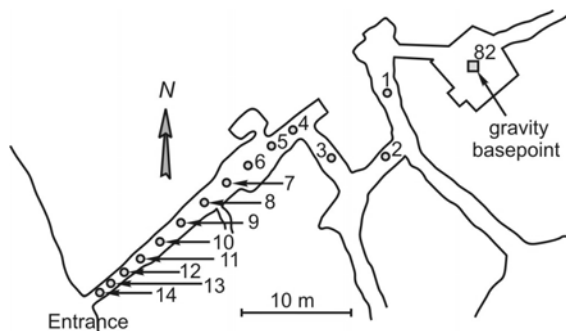

Fig. 9. The torsion balance microbase points

First we tried to use the E54 torsion balance, but after some attempt it turned out that this instrument was not suitable for us, because its measuring range (O: 0-170; []: 200-370 scale unit) not enough wide to measure the very large variation of gravity gradients in the Mátyás cave. Because the measuring range of the Auterbal torsion balance is much wider (O: 0-280; []: 280-560) so this instrument was applied.

During our measurements many different problems occurred. The permanently extant 11°C temperature was advantageous for the

drift but that humid and could air was very adverse for the turning mechanism and the clockwork of the torsion balance. The O and [] torsion balances should be adjusted asymmetrical several times because of the extremely high values of gravity gradients. On three points near to the entrance of the cave the wider measuring range of the Auterbal torsion balance was not even enough to measure the very large gravity gradients.

Results of our measurements started from the gravity base point 82 to the endpoint of the gravity microbase 82/11 are summarized on the Fig. 10. On the upper part of the figure the horizontal gradients of gravity W_{xz} and W_{yz} , on the lower part the curvature data W_{Δ} and W_{xy} , can be seen. As it was mentioned above there are two independent antiparallel torsion balances inside the balance box seven cm distance from each other, so we get two independent observations for each gravity gradients and curvature data at each torsion balance station. Supposing errorless measurements the two independent observations should be the same, and the occasional differences give information about the reliability of the measurements. Both the measured data of the O and the [] balance and their mean values marked by dashed line can be well distinguished on the Fig. 10. Analyzing the differences of the O and the [] independent balances it can be find that the repeated observations on the gravity base point 82 the same gradient values was observed by the O and the [] balances, but going towards to the entrance of the cave bigger and bigger differences can be measured by the two balances. The gravity base point can be found in the middle of a big hall relatively far from masses, but going towards to the entrance the microbase points are closer and closer to the disturbing masses, and the gradients are so large here, which gives measurable differences of gravity gra-

dients by the O and the [] balances (Ulmann, 2009).

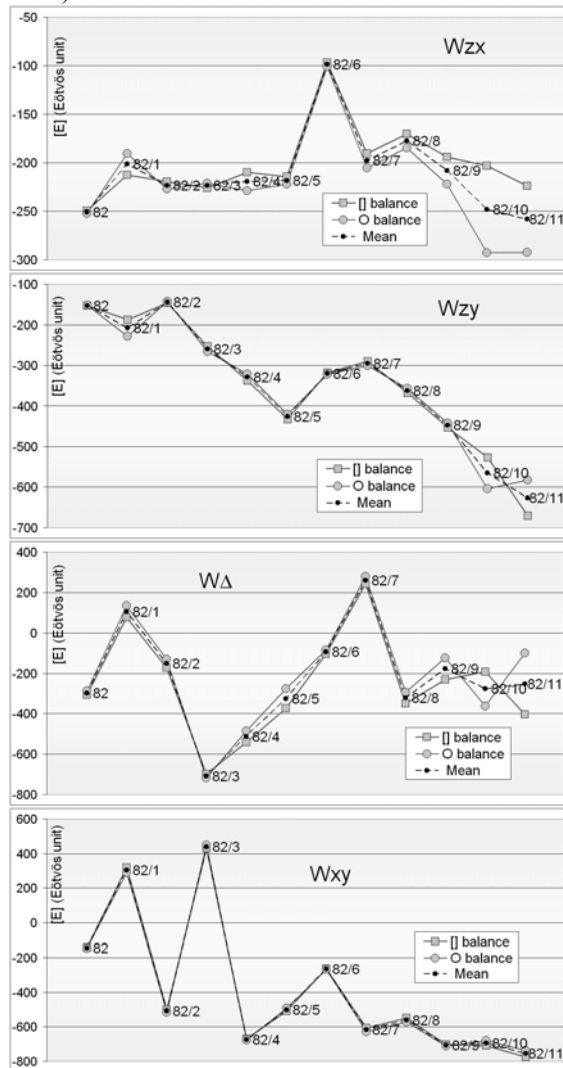

Fig. 10. Results of the torsion balance measurements

7 Summary

Before the end of the 1960's approximately 60,000 torsion balance measurements were made in Hungary. Recent research on the field of their geodetic applications showed the need for new observations.

After an interruption of half a century, torsion balances are operated again in Hungary. Following the renovation and modernization of an Auterbal and an E54 balance, measurements are taking place in the Mátyás cave.

Gravity gradiometry was introduced by Lorand Eötvös by creating his famous instrument in the beginning of the 1900's, but nowadays it is playing important role in geodesy again. Torsion balance measurements will be important and indispensable

data source for the determination of small wavelength gravity field and geoid features in Hungary.

A group of professionals has been formed again who have the intent to continue the scientific efforts of Lorand Eötvös, are able to renovate and modernize obsolete instruments, and have the field experience to continue torsion balance measurements.

Acknowledgements

Our investigations are supported by the National Scientific Research Fund (OTKA K-76231).

References

- Csapó G. (1991): Δg and vertical gradient measurements by LCR gravimere and observations by E54 torsion balance on the microbase of ELGI in the Mátyás cave. (ELGI datastore).*
- Csapó G, Völgyesi L (2004): New measurements for the determination of the local vertical gradients. *Magyar Geofizika*, 45, 2, (64-69).*
- Dobróka M, Völgyesi L (2008): Inversion reconstruction of gravity potential based on gravity gradients. *Mathematical Geosciences*, 40, (3). 299-311.
- Eötvös R. (1906) Bestimmung der Gradienten der Schwerkraft und ihrer Niveaflächen mit Hilfe der Drehwaage. *Verhandl. d. XV. allg. Konferenz der Internat. Erdmessung in Budapest.*
- Haalck H (1950): Die vollständige Berechnung örtlicher gravimetrischer Störfelder aus Drehwaagemessungen. *Veröffentlichungen des Geodätischen Institutes Potsdam*, Nr. 4, Potsdam.
- Polcz I (2003): The history of the Lorand Eötvös Geophysical Institute I. ELGI (külön kiadvány)*
- Tóth Gy, Völgyesi L, Csapó G (2005): Determination of vertical gradients from torsion balance measurements. *IAG Symposia Vol 129, Gravity, Geoid and Space Missions*, C. Jekeli, L. Bastos, J. Fernandes (Eds.), Springer, 292-297.
- Tóth Gy (2007): Vertical gravity gradient interpolation in a grid of Eötvös torsion balance measurements. *Geomatikai Közlemények X*. 29-36.*
- Ulmann Z (2009): Investigation of the gradients of gravity in the Mátyás cave. *Diplomawork, BME Építőmérnöki Kar*.*
- Völgyesi L (1993): Interpolation of Deflection of the Vertical Based on Gravity Gradients. *Periodica Polytechnica Civ.Eng.*, Vol. 37. Nr. 2, (137-166).
- Völgyesi L (1995): Test Interpolation of Deflection of the Vertical in Hungary Based on Gravity Gradients. *Periodica Polytechnica Civ.Eng.*, Vol. 39, Nr. 1, (37-75).
- Völgyesi L (2001a): Local geoid determinations based on gravity gradients. *Acta Geodaetica et Geophysica Hung.* Vol. 36 Nr. 2, pp. 153-162.
- Völgyesi L (2001b): Geodetic applications of torsion balance measurements in Hungary. *Reports on Geodesy, Warsaw University of Technology*, Vol. 57, Nr. 2, pp. 203-212
- Völgyesi L, Tóth Gy, Csapó G (2004): Determination of gravity anomalies from torsion balance measurements. *Gravity, Geoid and Space Missions GGSM 2004*. Springer Verlag, Berlin, Heidelberg, New York; Vol. 129. (292-297).
- Völgyesi L (2005): Deflections of the vertical and geoid heights from gravity gradients. *Acta Geodaetica et Geophysica Hungarica*, 40, 2 (147-159).
- Völgyesi L, Tóth Gy, Csapó G, Szabó Z (2005): The present state of geodetic applications of Torsion balance measurements in Hungary. *Geodézia és Kartográfia*, 57(5), 3-12.*

* (in Hungarian)

* * *

Völgyesi L, Ulmann Z (2012): [Reconstruction of a torsion balance, and the results of the test measurements](#). In: S. Kenyon, M.C.Pacino, U Marti (Eds.) Geodesy for Planet Earth, Buenos Aires, Argentina. 2009. International Association of Geodesy Symposia, Vol. 136, Springer-Verlag; Berlin, Heidelberg, ISBN: 978-3-642-20337-4. pp. 281-289.

Dr. Lajos VÖLGYESI, Department of Geodesy and Surveying, Budapest University of Technology and Economics, H-1521 Budapest, Hungary, Műgyetem rkp. 3.
Web: <http://www.agt.bme.hu/volgyesi> E-mail: volgyesi@eik.bme.hu